

# Compressor Installation Procedures

**PROTECT YOUR INVESTMENT... DO IT RIGHT THE 1ST TIME  
THERE ARE NO SHORT CUTS TO A/C REPAIR!**

**WARNING: FAILURE TO FOLLOW THESE  
STEPS WHEN INSTALLING THE COMPRESSOR  
WILL VOID YOUR WARRANTY**

Se incluye versión española.  
Version française incluse.  
Deutsche Version ist enthalten.

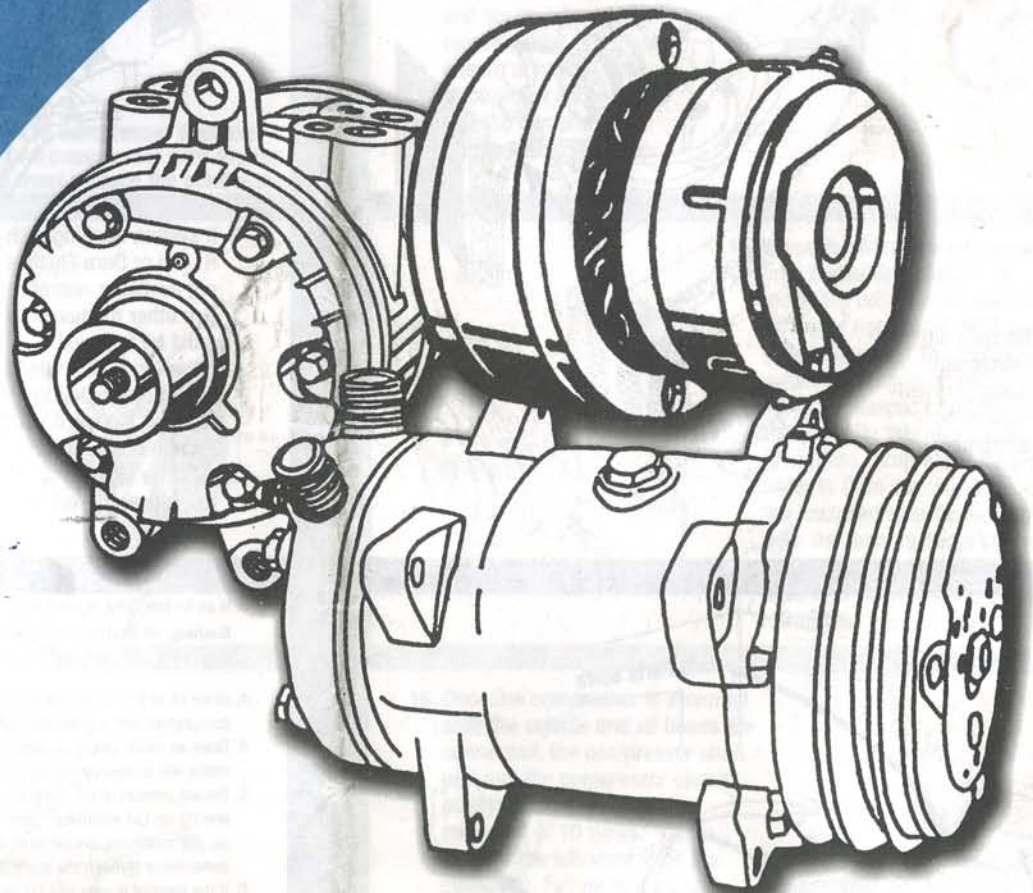

**Note:** Most remanufactured compressors do not contain oil. If the compressor packaged in this box is a new compressor, check the tape on the compressor to determine whether the compressor is charged with lubricant; some new compressors are shipped with a full system charge of lubricant.

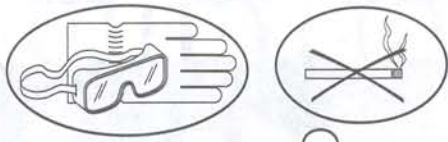

### 1. Safety Hints:

- Failure to follow proper service procedures may result in personal injury and/or property damage. It is the responsibility of the installer to adhere to all federal, state and local laws and/or regulations that may govern motor vehicle air conditioning refrigerants.
- Do NOT Smoke While Performing A/C Repair
- Do NOT Drop Compressor
- Use Safety Goggles & Gloves While Handling Refrigerant



**Note:** On Ford products with an FS10 or an FX15 compressor that has had a major failure, or GM products with a DA6 compressor with broken Teflon rings and a dual path condenser, you must replace the condenser.

4. You must clean this A/C system with an approved flush. We recommend R141b or Dura Flush for use as an approved flushing solvent. Do not use petroleum based solvents or alcohol. Do not use flammable solvents. For proper flushing, you must disconnect hoses from items that are not to be flushed.

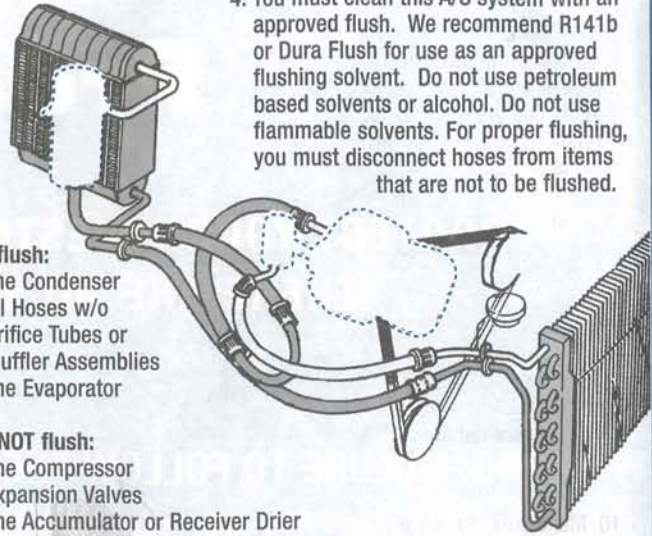

#### Do flush:

- The Condenser
- All Hoses w/o Orifice Tubes or Muffler Assemblies
- The Evaporator

#### Do NOT flush:

- The Compressor
- Expansion Valves
- The Accumulator or Receiver Drier
- Hose Assemblies w/either Filters or Muffler Assemblies

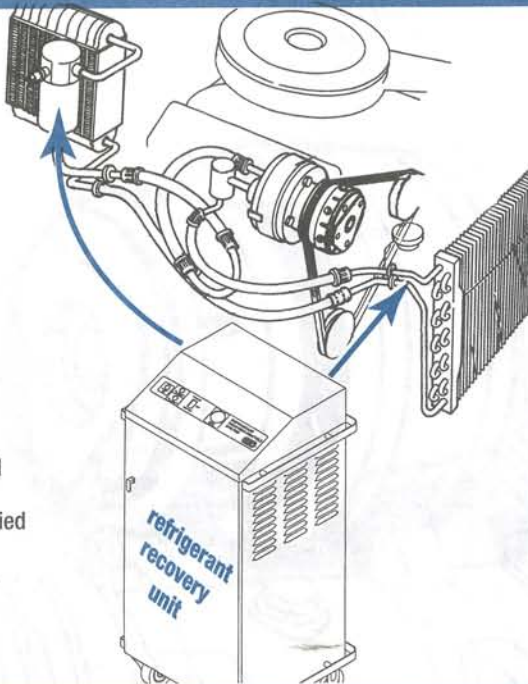

2. Reclaim old refrigerant using certified reclaiming equipment.

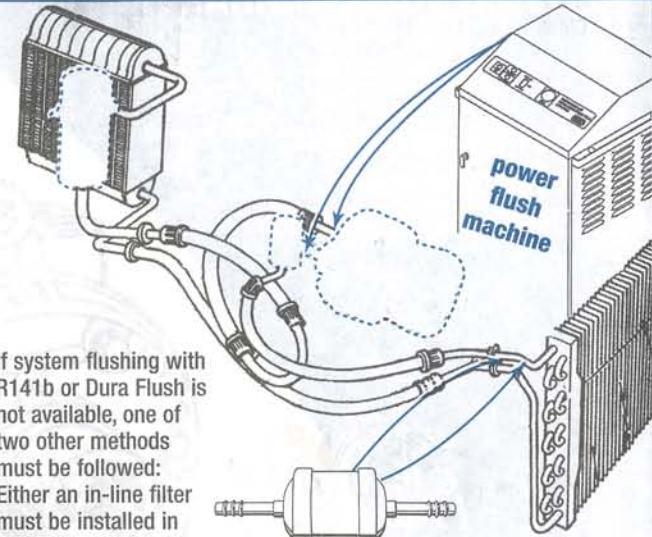

5. If system flushing with R141b or Dura Flush is not available, one of two other methods must be followed: Either an in-line filter must be installed in the high side of the A/C system or the system must be cleaned using power flush equipment.

**in-line filter**

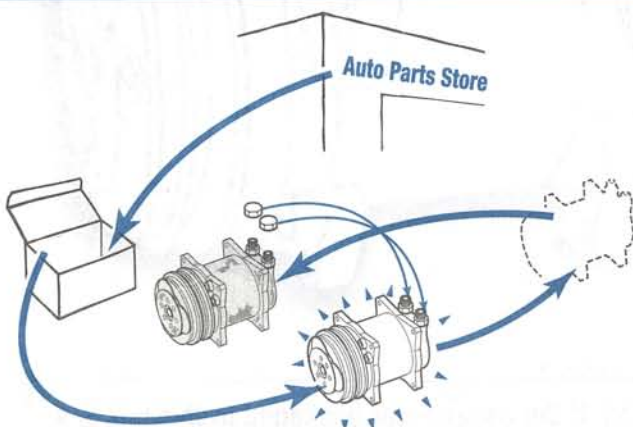

3. Remove old compressor from vehicle and transfer any switches or brackets from old compressor to new compressor.

6. If an in-line filter is used in place of flushing, oil charging must be handled differently and carefully.

- Drain all of the old oil out of the old compressor into a graduated cylinder.
- Drain as much oil out as possible, rotate the compressor if necessary.
- Record amount of oil, if it is less than one (1) oz. (34 milliliters), then add 2 oz. (68 milliliters) of new oil to the new compressor through the suction port.
- If the amount is over one (1) oz. (34 milliliters), add the same amount drained through the suction port of the compressor.
- Accumulator (must be replaced): Drain the old lubricant from the old drier or accumulator. Add the same amount drained, plus two (2) additional oz. (68 milliliters) to the new accumulator/filter drier.
- Evaporator (optional): Add three (3) oz. (100 milliliters) to the new evaporator.
- Condenser (optional): Add one (1) oz. (34 milliliters) to the new condenser.

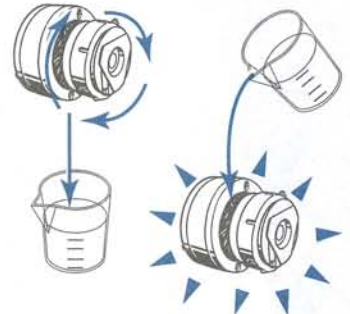

Be sure not to over oil or under oil the A/C system using this method. It may cause system failure.

7. The receiver drier or accumulator drier must be replaced.

8. The orifice tube at evaporator inlet, condenser outlet or in liquid line must be replaced (if the vehicle is so equipped).

9. The thermostatic expansion valve must be inspected for debris or metal particles. Any restrictions will lead to poor performance or premature compressor failure.

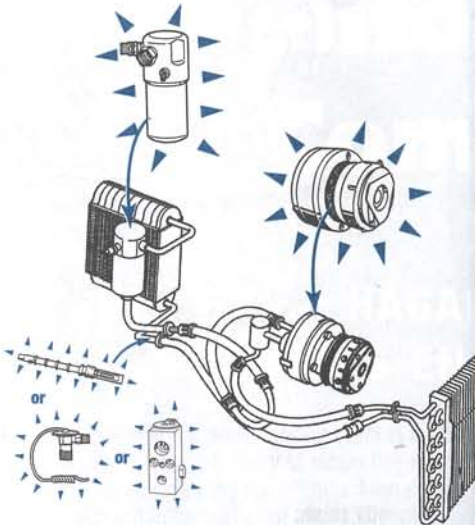

10. Make sure you have clear air flow through the A/C condenser and the vehicle's radiator. Clean all bugs and debris off of the condenser. Check coolant level and condition. Inspect air dams and condenser/radiator seals.

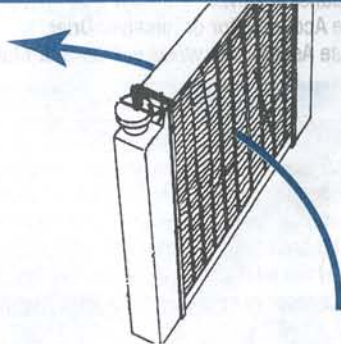

**Note:** On Ford products with an FS10 or an FX15 compressor that has had a major failure, or GM products with a DA6 compressor with broken Teflon rings and a dual path condenser, you must replace the condenser.

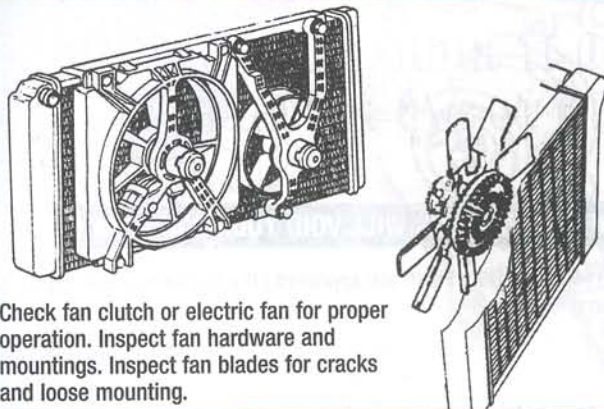

11. Check fan clutch or electric fan for proper operation. Inspect fan hardware and mountings. Inspect fan blades for cracks and loose mounting.

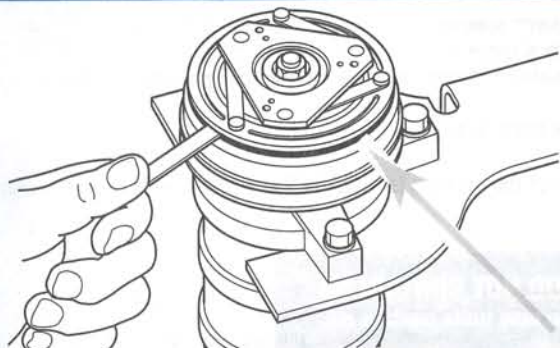

12. Check the compressor clutch air gap before installation. The gap is pre-set at the factory, however it may become out of adjustment during shipping and handling. Failure to check gap may lead to premature clutch failure. Refer to OEM specifications or the enclosed specification sheet from the manufacturer.



13. The proper amount and correct type of lubricant are critical. CFC12 systems use mineral oil and HFC134a systems use polyalkylene glycol (i.e. PAG) or polyol ester (i.e. POE, ester) lubricants. Lubricants are not cross-compatible and cannot be substituted for each other. Refer to the Original Equipment Manufacturer's specifications or the compressor manufacturer's specifications enclosed with the compressor for proper oil charges.

14. It is recommended that the oil charge be split between various locations in the vehicle's A/C system. An equal portion of the total oil charge should be placed into the suction side of the compressor and accumulator or receiver drier. This will ensure proper oil flow through the A/C system and the compressor during system start-up.

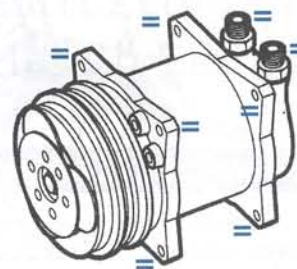
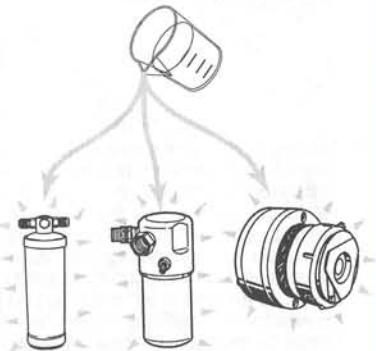

15. When mounting the compressor onto the vehicle, tighten all mounting bolts evenly and DO NOT over tighten. DO NOT use an impact wrench. The aluminum cases on many compressors can easily be warped or distorted. Failure to do this may cause premature compressor failure. Refer to OEM specifications or the enclosed specification sheet from the manufacturer. Lubricate all fittings and seals with mineral oil or o-ring lube, even when retrofitting.

16. Once the compressor is mounted onto the vehicle and all hoses are connected, the compressor shaft (not just the compressor clutch pulley) must be rotated a minimum of 10 times. This is to clear the lubricant from the cylinders. Failure to correctly perform this procedure will cause premature compressor failure. In many instances a spanner wrench will be needed for this procedure. DO NOT turn the compressor clutch nut, you may inadvertently change the clutch air gap. This too may cause premature clutch failure.

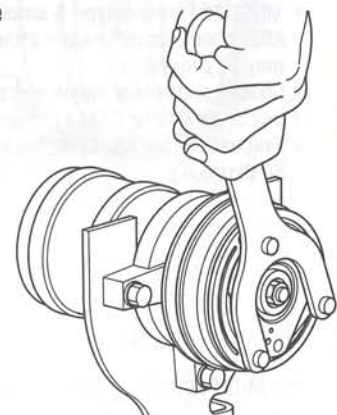

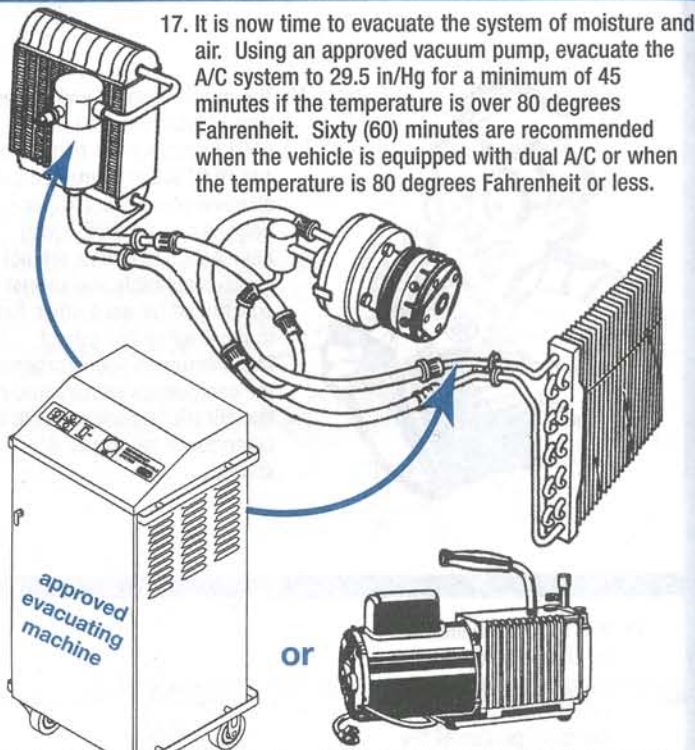

17. It is now time to evacuate the system of moisture and air. Using an approved vacuum pump, evacuate the A/C system to 29.5 in/Hg for a minimum of 45 minutes if the temperature is over 80 degrees Fahrenheit. Sixty (60) minutes are recommended when the vehicle is equipped with dual A/C or when the temperature is 80 degrees Fahrenheit or less.

18. Recharging the system is next. Remember, only R12 or R134a are approved refrigerants for the compressor. Only R12 or R134a will maintain system integrity and compressor warranty. The use of an unapproved refrigerant will automatically void the compressor warranty. Use a scale or meter to charge with refrigerant. DO NOT charge by gauges alone. The correct charge of R12 or R134a is critical for proper performance. If the replacement charge is replacing a like refrigerant, use the recommended OEM charge. If the compressor is being utilized in a retrofit to R134a, please refer to either the Original Equipment Manufacturers' or compressor manufacturers' retrofitting procedures. If the vehicle is being retrofitted, DO NOT charge the system to the capacity listed for R12 as it will automatically overcharge the system, resulting in elevated high side pressures and probable premature compressor failure.

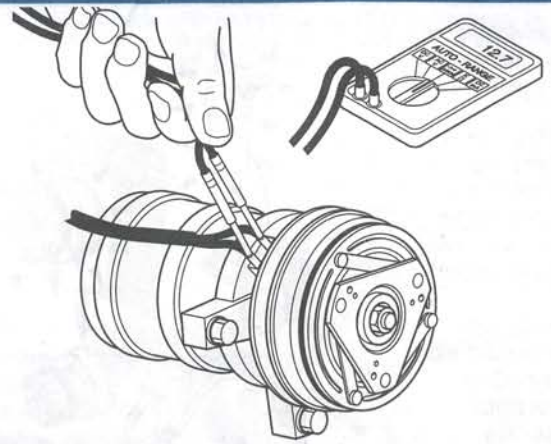

19. It is important to check the compressor clutch electrical circuit. Use a volt meter to check for proper clutch voltage. If the proper voltage is not found, it may cause premature clutch failure. (Check OEM specifications for proper clutch voltage.) It is recommended that the clutch be burnished to increase the grip between the compressor clutch plates. With the engine at approximately 2000 RPM, cycle the compressor clutch off and on twenty times using the A/C control switch on the dash. This will enhance compressor and compressor clutch performance.

**Note:**

If the A/C system has experienced a catastrophic compressor failure, the condenser should immediately be suspect for replacement. If a pyrometer is available, the inlet and outlet should be checked for a dramatic drop in temperature. Anything over a 60-degree drop between the inlet and outlet indicates that either further flushing of the condenser is needed or condenser replacement may be required.

Refrigerant seepage around the compressor shaft seal is normal for the first few hours of operation.

## PROTECT YOUR INVESTMENT... DO IT RIGHT THE 1ST TIME THERE ARE NO SHORT CUTS TO A/C REPAIR!

### FAILURE TO FOLLOW THESE 12 STEPS WHEN INSTALLING THE COMPRESSOR WILL VOID YOUR WARRANTY

- **MUST** clean A/C system with an approved flush, using an approved flushing method (R141b and Dura Flush are approved.) If a manufacturer's approved flushing solvent is not available, an in-line filter **MUST** be installed per these instructions.
- **MUST** replace filter drier or accumulator drier.
- **MUST** replace orifice tube or liquid line that contains orifice tube (if applicable.)
- Inspect / replace thermostatic expansion valve & clean inlet screen (if applicable.)
- Check for proper airflow through cooling fins of condenser & radiator (condenser may need to be replaced, refer to enclosed instructions for further details)
- Check for proper fan clutch or electric fan operation.
- Check compressor clutch air gap before installation (refer to OEM or compressor manufacturer's specs.)
- **MUST** add correct type & amount of refrigerant oil (refer to OEM or compressor manufacturer's specs.)
- After hose assemblies are attached, turn compressor shaft (not just the clutch pulley) minimum of 10 times to clear oil from compressor (a spanner wrench may be required.)
- Check compressor clutch electrical circuit for proper voltage (use either OEM or compressor manufacturer's specs.)
- Use **ONLY** R12 or R134a refrigerant.
- Evacuate entire A/C system for minimum of 45 minutes if the temperature is above 80 degrees (60 minutes for Dual Air System or if temperature is below 80 degrees.)

**MOST REMANUFACTURED COMPRESSORS DO NOT CONTAIN OIL.**  
Make sure this compressor is not a new unit, some new units contain oil.

You **MUST** add oil per OEM or compressor manufacturer's recommendations.